



# GP 645

## 6V 4.5Ah

GP 645 is a general purpose battery up to 5 years in standby service or more than 260 cycles at 100% discharge in cycle service. As with all CSB batteries, all are rechargeable, highly efficient, leak proof and maintenance free.



### Specification

Cells Per Unit	3
Voltage Per Unit	6
Capacity	4.5Ah @ 20hr-rate to 1.75V per cell @25 °C (77°F)
Weight	Approx. 0.84 kg(1.85 lbs)
Maximum Discharge Current	60A/90A(5sec)
Internal Resistance	Approx. 19 mΩ
Operating Temperature Range	Discharge: -15°C~50°C ( 5°F~122°F) Charge: -15 °C~40°C ( 5°F~104°F) Storage: -15°C~40°C ( 5°F~104°F)
Nominal Operating Temperature Range	25°C±3°C(77°F±5°F)
Float Charging Voltage	6.75 to 6.9 VDC/unit Average at 25°C(77°F)
Recommended Maximum Charging	1.35A
Current Limit	
Equalization and Cycle Service	7.2 to 7.5 VDC/unit Average at 25°C(77°F)
Self Discharge	CSB Batteries can be stored for more than 6 months at 25°C(77°F). Please charge batteries before using. For higher temperatures the time interval will be shorter.
Terminal	F1/F2-Faston Tab187/250
Container Material	ABS(UL 94-HB/File E50263)*Flammability resistance of (UL 94-V0/File E88637) can be available upon request.

### Dimensions

unit:(MM)

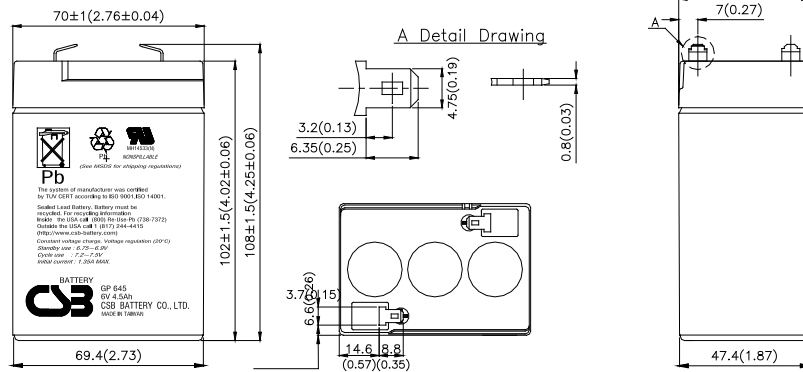

CSB-manufactured batteries are UL-recognized components under UL924 and UL1989. CSB is also certified by ISO 9001 and ISO 14001.

### Constant Current Discharge Characteristics Unit:A (25°C,77°F)

F.V/Time	5MIN	10MIN	15MIN	30MIN	1HR	2HR	3HR	4HR	5HR	8HR	10HR	20HR
1.60V	18.7	12.3	9.08	5.37	3.11	1.80	1.26	0.994	0.810	0.535	0.439	0.234
1.67V	17.6	11.8	8.89	5.31	3.10	1.79	1.25	0.987	0.808	0.533	0.438	0.233
1.70V	17.0	11.6	8.79	5.28	3.08	1.78	1.24	0.984	0.807	0.532	0.437	0.232
1.75V	16.1	11.2	8.62	5.22	3.06	1.77	1.23	0.979	0.804	0.531	0.435	0.229
1.80V	15.0	10.7	8.42	5.13	3.03	1.76	1.22	0.975	0.801	0.529	0.431	0.225
1.85V	13.8	10.3	8.22	5.05	3.00	1.75	1.21	0.971	0.798	0.528	0.428	0.221

### Constant Power Discharge Characteristics Unit:W (25°C,77°F)

F.V/Time	5MIN	10MIN	15MIN	30MIN	1HR	2HR	3HR	4HR	5HR	8HR	10HR	20HR
1.60V	112	73.5	54.5	32.2	18.7	10.8	7.55	5.96	4.86	3.21	2.64	1.41
1.67V	105	70.4	53.4	31.8	18.6	10.7	7.52	5.94	4.85	3.20	2.63	1.40
1.70V	102	69.2	52.7	31.6	18.5	10.6	7.50	5.93	4.84	3.19	2.62	1.39
1.75V	96.0	66.8	51.8	31.3	18.4	10.5	7.48	5.91	4.83	3.18	2.61	1.38
1.80V	90.0	64.0	50.5	30.8	18.2	10.4	7.45	5.89	4.81	3.17	2.59	1.35
1.85V	82.5	61.3	49.3	30.3	18.0	10.3	7.43	5.87	4.80	3.16	2.57	1.33

• All mentioned values are average values.

### Trickle (or Float) Service Life

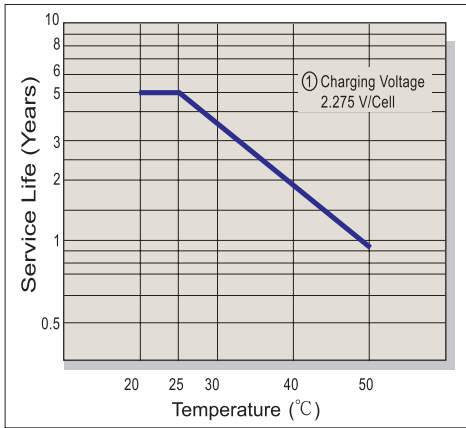

### Capacity Retention Characteristic

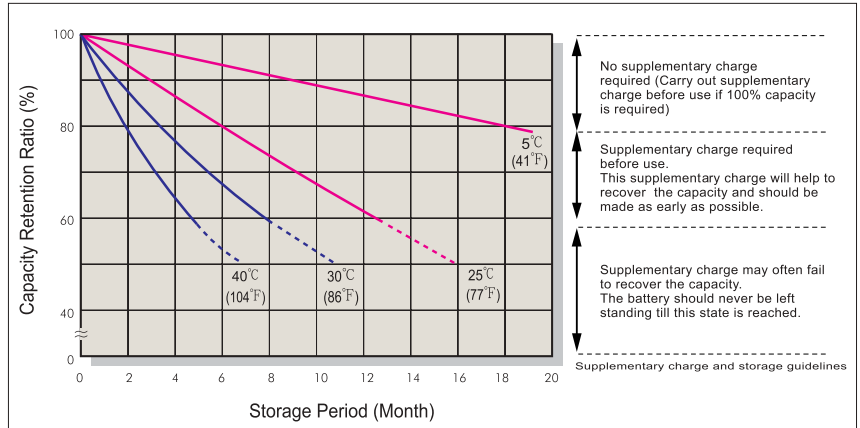

### Battery Voltage and Charge Time for Standby Use

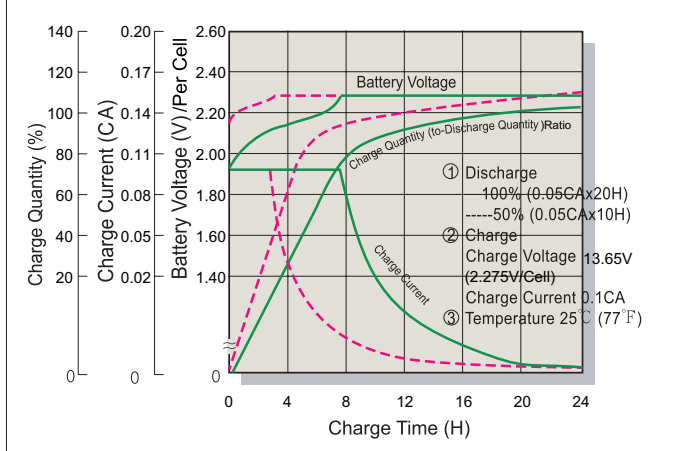

### Cycle Service Life

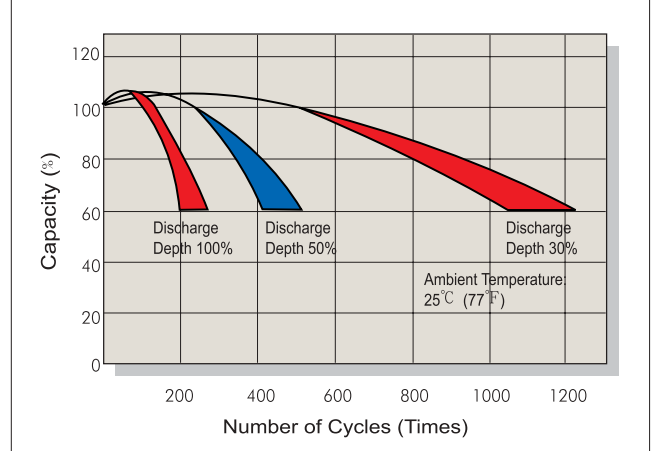

### Battery Voltage and Charge Time for Cycle Use

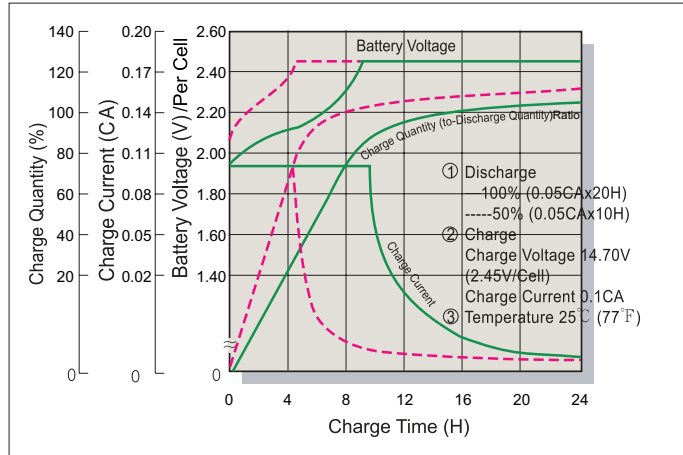

### Terminal Voltage (V) and Discharge Time

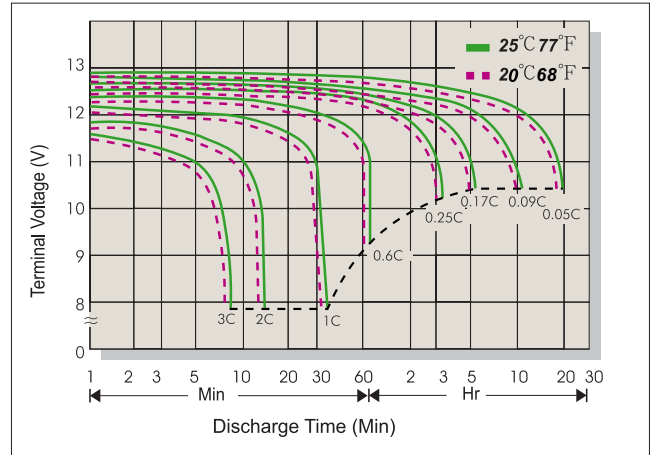

### Charging Procedures

Application	Charge Voltage(V/Cell)			Max.Charge Current
	Temperature	Set Point	Allowable Range	
Cycle Use	25°C(77°F)	2.45	2.40~2.50	0.3C
Standby	25°C(77°F)	2.275	2.25~2.30	

### Discharge Current VS. Discharge Voltage

Final Discharge Voltage V/Cell	1.75	1.70	1.60	1.30
Discharge Current(A)	0.2C>(A)	0.2C<(A)<0.5C	0.5C<(A)<1.0C	(A)>1.0C

Sales Office [URL:WWW.CSB-BATTERY.COM](http://WWW.CSB-BATTERY.COM)

**CSB BATTERY CO., LTD.**  
TAIWAN OFFICE  
Tel: +886-2-2555-5600  
Fax: +886-2-2555-3300  
E-mail: service@csb-battery.com.tw

**CSB BATTERY LOGISTICS (SHANGHAI) CO., LTD.**  
SHANGHAI OFFICE  
Tel: +86-21-5046-1622, 5046-0833  
Fax: +86-21-5064-3314  
E-mail: chinasis@csb-battery.com

**CSB BATTERY TECHNOLOGIES, INC**  
USA OFFICE  
Tel: +1-817-244-7777/1-8003 CSBUSA(272872)  
Fax: +1-817-244-4445  
E-mail: csb@csb-battery.com

**CSB BATTERY LOGISTICS (SHANGHAI) CO., LTD.**  
BEIJING OFFICE  
Tel: +86-10-6597-8060, 6597-8070  
Fax: +86-10-6597-8050  
E-mail: chinasis@csb-battery.com

**CSB BATTERY OF NETHERLANDS B.V**  
NETHERLANDS OFFICE  
Tel: +31(0) 180 418 140  
Fax: +31(0) 180 418 327  
E-mail: eurosales@csb-battery.com

**CSB BATTERY LOGISTICS (SHANGHAI) CO., LTD.**  
SHENZHEN OFFICE  
Tel: +86-755-8831-6488/6396/16356  
Fax: +86-755-8831-6548  
E-mail: she@csb-battery.com.cn